

AMC758

Intel Xeon E3 Processor AMC, PCIe Gen3



AMC758

Key Features

- Processor AMC Intel® Xeon® Processor E3-1505M v6 (Kaby Lake)
- 64 GB of Flash memory with dual M.2 NVMe storage sockets
- Dual 10GbE via SFP+ and dual GbE on the front panel
- Dual Graphic output (DP++) and dual USB 3.0
- PCIe Gen3 x4 on ports 4-7 and 8-11 or single PCIe x8 on ports 4-11 (AMC.1)
- 16 GB of DDR4 memory with ECC
- Double module, mid-size (option for full-size) per AMC.0

Benefits

- High performance Xeon E3-1505M processor with CM238 PCH
- Design utilizes proven VadaTech subcomponents and engineering techniques
- Electrical, mechanical, software, and system-level expertise in house
- Full system supply from industry leader
- AS9100 and ISO9001 certified company

AdvancedMC™



vadatech
THE POWER OF VISION



AMC758

The AMC758 is a Processor AMC (PrAMC) in a double module, mid-size AdvancedMC (AMC) form factor based on the Intel® Xeon® Processor E3-1505M v6 (Kaby Lake) with CM238 PCH. The processor base frequency is 3.0 GHz with max turbo frequency of 4.0 GHz. The module follows the AMC.1, AMC.2 and the AMC.3 specifications.

The module provides dual PCIe Gen3 x4 or single x8 on ports 4-11 per AMC.1, GbE on ports 0 and 1 per AMC.2, and SATA on ports 2 and 3 per AMC.3.

The AMC758 provides dual 10GbE via SFP+ and dual GbE to the front panel. The module also has dual M.2 NVMe storage option which connects to the CPU via PCIe x4.

The AMC758 provides up to 16 GB of DDR4 memory with ECC and 64 GB of Flash for the OS. The module has Serial over LAN (SoL). The BIOS allows booting from on-board Flash, off-board SATA, PXE boot and USB. There are dual USB 3.0 type C connectors for extended storage or peripherals. Linux OS is standard on the AMC758, consult VadaTech for other options.



Figure 1: AMC758

Block Diagram

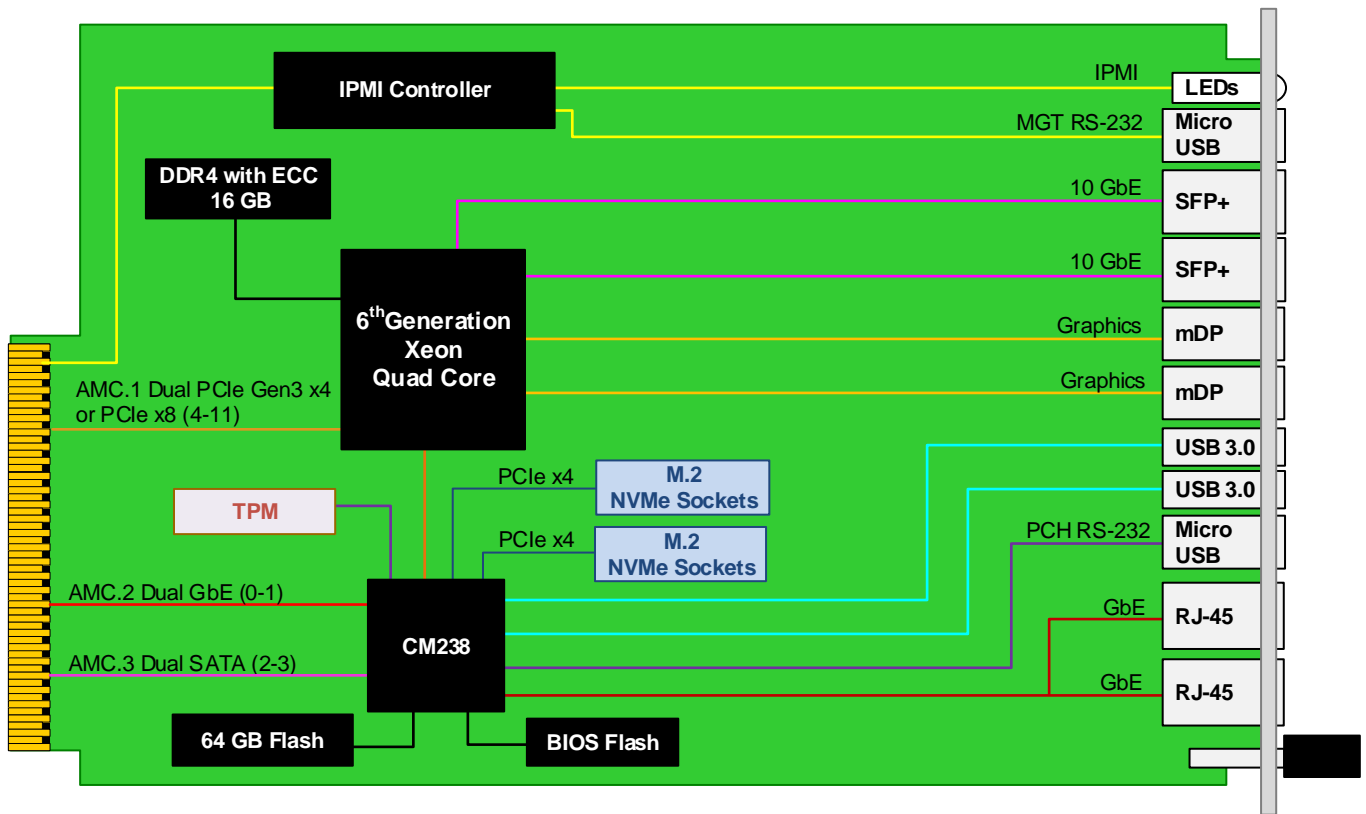

Specifications

Architecture	
Physical	Dimensions Width: 5.85" (148.5 mm)
	Depth: 7.11" (180.6 mm)
Type	AMC Processor Intel Xeon E3 Processor AMC, Quad Core, 4.0 GHz
Standards	
AMC	Type AMC.0, AMC.1, AMC.2 and/or AMC.3
Module Management	IPMI IPMI v2.0
PCIe	Lanes Single x8 or dual x4 as PCIe Gen3
Configuration	
Power	AMC758 ~65 W
Environmental	Temperature See ordering options and environmental spec sheet Storage Temperature: -40° to +90°C
	Altitude Chassis dependent
	Relative Humidity 5 to 95% non-condensing
Front Panel	Interface Connectors 2x RJ-45 for GbE and 2x SFP+ for 10GbE
	2x USB type C connectors for USB 3.0
	2x Micro USB for RS-232
	2x Mini DisplayPort for graphics
	LEDs IPMI, activity and user defined
	Mechanical Hot swap ejector handle
Software Support	Operating System Linux (consult VadaTech for other options)
Other	
MTBF	MIL Hand book 217-F@ TBD hrs
Certifications	Designed to meet FCC, CE and UL certifications, where applicable
Standards	VadaTech is certified to both the ISO9001:2000 and AS9100B:2004 standards
Warranty	Two (2) years

INTEGRATION SERVICES AND APPLICATION-READY PLATFORMS

VadaTech has a full ecosystem of OpenVPX, ATCA and MTCA products including chassis platforms, shelf managers, AMC modules, Switch and Payload Boards, Rear Transition Modules (RTMs), Power Modules, and more. The company also offers integration services as well as pre-configured Application-Ready Platforms. Please contact VadaTech Sales for more information.

Ordering Options

AMC758 – ABC-DEF-00J

A = DDR4 Memory 0 = Reserved 1 = 16 GB	D = NVMe Storage Socket One 0 = No NVMe 1 = 512 GB 2 = 1 TB 3 = 2 TB	
B = Flash Storage 0 = Reserved 1 = 64 GB	E = NVMe Storage Socket Two 0 = No NVMe 1 = 512 GB 2 = 1 TB 3 = 2 TB	
C = Front Panel Size 1 = Reserved 2 = Mid-size 3 = Full-size 4 = Reserved 5 = Mid-size, MTCA.1 (captive screws) 6 = Full-size, MTCA.1 (captive screws)	F = SFP+ Transceivers** 0 = No TxCVRs 1 = SR 2 = LR 3 = 10GbE Copper	J = Temperature Range and Coating* 0 = Commercial (–5° to +55° C), No coating 1 = Commercial (–5° to +55° C), Humiseal 1A33 Polyurethane 2 = Commercial (–5° to +55° C), Humiseal 1B31 Acrylic 3 = Industrial (–20° to +70° C), No coating 4 = Industrial (–20° to +70° C), Humiseal 1A33 Polyurethane 5 = Industrial (–20° to +70° C), Humiseal 1B31 Acrylic 6 = Extended (–40° to +85° C), Humiseal 1A33 Polyurethane 7 = Extended (–40° to +85° C), Humiseal 1B31 Acrylic

Notes: *Edge of module for conduction cooled boards, consult factory for availability
 **Two identical are included (for other combinations please contact VadaTech Sales)

Related Products

UTC004



- Unified 1 GHz quad-core CPU for MCMC, Shelf Manager, Clocking, and Fabric management
- Automatic fail-over with redundant UTC004s
- Full Layer 2 or 3 managed Ethernet switches

UTC020



- Single module, full-size per AMC.0
- Dual -36 V DC to -75 V DC input, 936 W (available in 468 W)
- Hot swappable with support for power module redundancy

VT853



- MicroTCA 1U 19" rack mount chassis platform
- Six mid-size AMC slots per 1U Carrier or two double module mid-size with two mid-size AMC slots
- Front to back cooling

Contact

VadaTech Corporate Office

198 N. Gibson Road, Henderson, NV 89014
Phone: +1 702 896-3337 | Fax: +1 702 896-0332

Asia Pacific Sales Office

7 Floor, No. 2, Wenhua Street, Neihu District, Taipei 114, Taiwan
Phone: +886-2-2627-7655 | Fax: +886-2-2627-7792

info@vadatech.com | www.vadatech.com

Europe: EMCOMO Solutions AG

Industriestr. 10, 89231 Neu-Ulm, Germany
Phone: +49 731 8803510 | Fax: +49 731 88035129

vadatech@emcomo.de | www.emcomo.de

Choose VadaTech

We are technology leaders

- First-to-market silicon
- Constant innovation
- Open systems expertise

We commit to our customers

- Partnerships power innovation
- Collaborative approach
- Mutual success

We deliver complexity

- Complete signal chain
- System management
- Configurable solutions

We manufacture in-house

- Agile production
- Accelerated deployment
- AS9100 accredited



vadatech
THE POWER OF VISION

Trademarks and Disclaimer

The VadaTech logo is a registered trademark of VadaTech, Inc. Other registered trademarks are the property of their respective owners. AdvancedTCA™ and the AdvancedMC™ logo are trademarks of the PCI Industrial Computers Manufacturers Group. All rights reserved. Specification subject to change without notice.

© 2018 VadaTech Incorporated. All rights reserved.
DOC NO. 4FM737-12 REV 01 | VERSION 1.1 – AUG/18